

## **Power Quality Improvement In Matrix Converter Using Hybrid Filter**

Archana.K<sup>1</sup>, Dr.Puttamadappa.C<sup>2</sup>

<sup>1</sup>(Assistant Professor, EEE dept, VVCE, Mysore)

<sup>2</sup>( Principal, Saphthagiri college of Engg, B'lore.)

**Abstract:** - This paper proposes a hybrid filter to minimize the power quality impact of matrix converters. Matrix converters inject significant harmonics and nonstandard frequency components into power systems. The hybrid filter is used to reduce the harmonics. A hybrid filter constructed of a shunt active filter and distributed passive filters used for power quality improvement. The proposed approach has been tested and validated on the matrix converter using Matlab/Simulink. The comparison of Simulation results for passive and active filter separately used with matrix converter with the result of matrix converter with hybrid filter is shown to demonstrate the advantages of the proposed scheme.

**Keywords:** - Current harmonics, Hybrid filter, Matrix Converter, Power quality.

### **I. INTRODUCTION**

There are many nonlinear loads drawing non sinusoidal currents from electrical power systems. These non sinusoidal currents pass through different impedances in the power systems and produce voltage harmonics. These voltage harmonics propagate in power systems and affect all of the power system components. The important harmonic source is ac/dc converters/inverters. The matrix converter is one of the harmonic source. Due to the discontinuous input currents, the matrix converter behaves as a source of current harmonics, which are injected back into the AC mains. Since these current harmonics results in voltage distortions that affect the overall operation of the AC system, they have to be reduced. Therefore, the proposed work necessitates the use of Hybrid Filters for improving the power quality of the matrix converter. A matrix converter with hybrid filter is simulated with MATLAB software. The simulation is done for the matrix converter without any filters, with usage of passive filter or active filters and the hybrid filter separately. Comparison of the waveforms of the system current in time domain proves that the effective power quality improvement of the matrix converter can be done by using the hybrid filter.

### **II. MATRIX CONVERTER**

#### **1. Introduction:**

Matrix converter belongs to direct frequency converter category. Output voltage is made by direct switching of input phases to output phases. This fact means that converter does not need DC-link capacitor which increases the costs and volume requirements of the converter. The absence of DC-link capacitor is one of the main advantages of the matrix converter. On the other hand it means that the output voltage amplitude is limited by 86.6% of the input voltage amplitude. Higher voltages can be achieved with over modulation, which causes input current distortion. The other advantages of the converter compared to conventional indirect frequency converter are: power factor regulation, operation in all four quadrants, its high dynamic, sinusoidal current consumption, nearly sinusoidal output voltage waveform with low harmonic content, and high efficiency.

It provides sinusoidal input and output waveforms. It has inherent bi-directional energy flow capability and the input power factor can be fully controlled. Last but not least, it has minimal energy storage requirements, which allows to get rid of bulky and lifetime-limited energy storing capacitors. The matrix converter consists of 9 bi-directional switches that allow any output phase to be connected to any input phase. The general architecture of the matrix converter is shown in Figure 1. Nine bi-directional switches in the matrix converter can theoretically assume 512 (2<sup>9</sup>) different switching states combinations. Taking into account that the converter is supplied by a voltage source and usually feeds an inductive load, the input phases should never be short-circuited and the output currents should not be interrupted. From a practical point of view these rules imply that one and only one bi-directional switch per output phase must be switched on at any instant. By this constraint, in a three to three phase matrix converter 27 switching combinations are permitted.

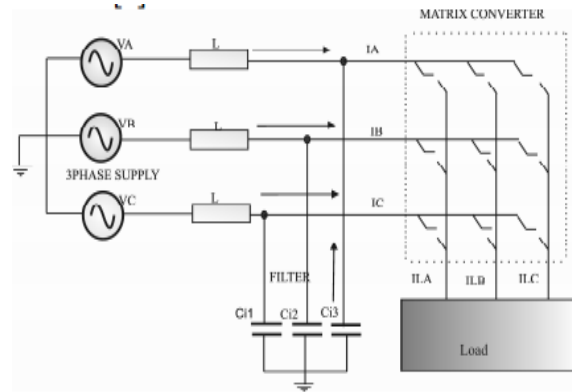

Fig. 1: General Architecture of Matrix Converter

### 1.1. Passive Filter:

Passive filters are classic methods for power quality improvement in ac of ac system consist of series LC tuned for removing a specific or harmonic or blocking a bandwidth of severe harmonics of nonlinear linear loads current. These filters have low impedances for the tuned frequencies such as 5<sup>th</sup> and 7<sup>th</sup> and for these frequencies, the lower impedance of the filter in comparison with system, the better filtering characteristics of passive filter. Low cost is a great benefit of these filters but because of their LC constant parameter, they cannot be efficient power quality improvement facilities for dynamic nonlinear loads. Another problem of installation of passive filters is probable resonances between the impedance of passive filter and the system resulting in increasing the harmonics and lower power quality of the ac system[2].

### 1.2. Active Filter:

The most popular type of active filters is the shunt active filter. Shunt active filters can be single-phase or three-phase, voltage source or current source. When the filter is used to compensate the current harmonics produced by the matrix converter, an active filter compensates the harmonic current of a matrix converter. Shunt active filters are used to compensate current harmonics of nonlinear loads to perform reactive power compensation and to balance imbalance currents. The matrix converter is considered as one type of load i.e. Current-Source Type of Harmonic Sources. Power electronics converters are a common and typical source of harmonic currents. The distortion of the current waveform, i.e., the generation of harmonics, results from the switching operation. Because of the harmonic current contents and characteristic are less dependent upon the AC side, this type of harmonic source behaves like a current source. Therefore, they are called current-source type of harmonic source (or harmonic current source) and represented as a current source. A shunt active filter is to be placed in parallel with a load (matrix converter) to detect the harmonic current of the load and to inject a harmonic current with the same amplitude of that of the load into the AC system. A shunt active filter senses the load current and injects a current into the system to compensate current harmonics or reactive load. In this paper a shunt filter was used to compensate the current harmonics of matrix converter, here the shunt active filter acts as a current source. The sum of its current and load current is the total current that flows through the source. Therefore, controlling the output current of the active filter can control the source current. High ratings of these filters lead to an increase in the costs.

### 1.3. Hybrid Filter:

Hybrid filters are constructed of active and passive filters with different structures used for removing the disadvantages of passive filters such as probability of resonances and non dynamic responses and also high costs of active filters, while using both the advantages of both of them with lower costs. Different structures of hybrid filters can be utilized in power systems such as shunt passive filter and series active power filter with nonlinear loads, shunt active and passive filter with nonlinear load, series active and passive filter parallel with nonlinear load, etc. are shown in Fig 2.

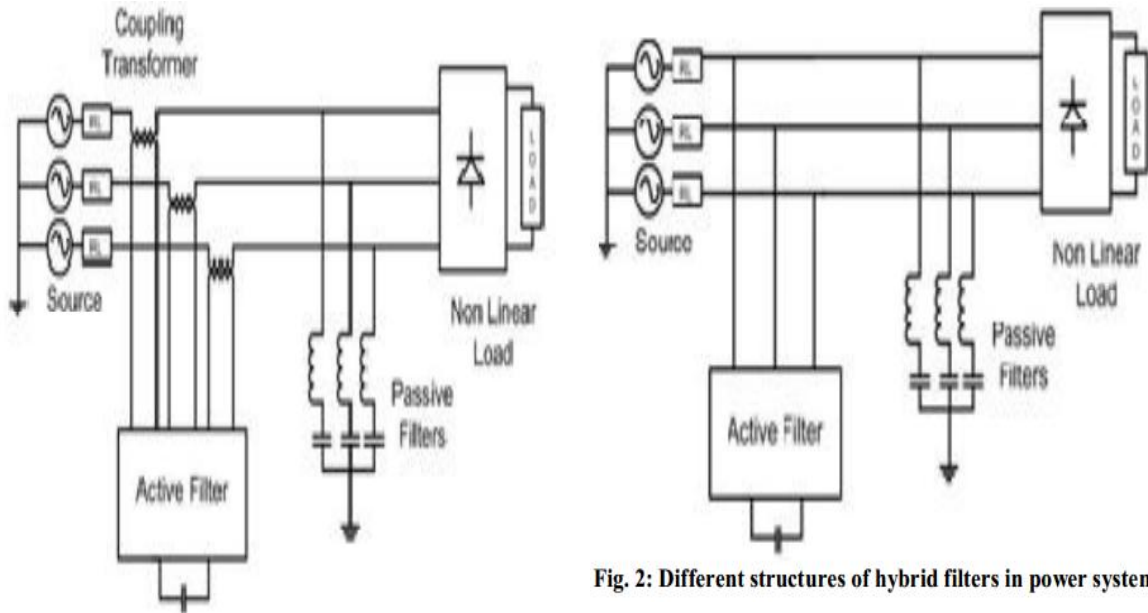

Fig. 2: Different structures of hybrid filters in power system

### III. THE PROPOSED COMPENSATION SCHEME FOR MATRIX CONVERTER

The objective of this work is to design a shunt hybrid passive-active filter to eliminate the load harmonics. The passive filter is connected in parallel with the load. It includes some LC branches that offer null impedance to the main current harmonics. The APF is connected in series with the passive filter. The scheme of the compensated system is presented in figure 3 given below. Figure 3 shows a three phase diagram of proposed shunt hybrid filter. Two passive branches are connected in series with an active filter with the help of three phase transformer.

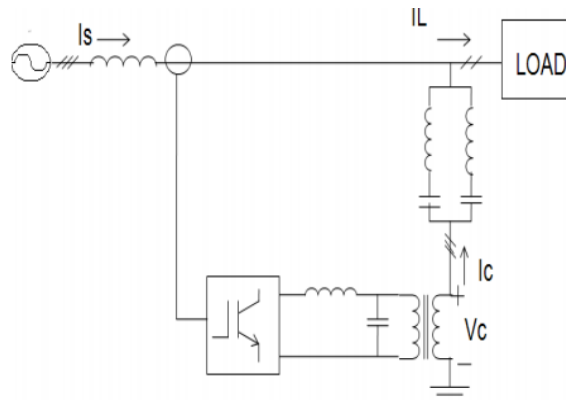

Fig. 3: Three phase system compensated with hybrid filter

If the active filter is not connected, the compensation current  $I_c$  mitigates the main harmonics of load current  $I_L$  and it is possible that a series resonance between the source impedance and the LC branches will appear. So the source current  $I_s$  will include certain harmonics and the distortion is not completely reduced. If the active filter is included an appropriate control allows to modify the impedance of shunt compensator at the resonance frequencies, and the problem can be avoided.

### IV. HYBRID FILTER DESIGN

The hybrid filter design depends on the load to be compensated. It must contain some passive LC branches one for each important load current harmonic to be removed from the source current. In the case of many typical loads, it is usually enough to employ one, two or three branches for the main harmonics. By three-phase systems it is possible to reduce or eliminate the 3<sup>rd</sup> harmonic order and its multiples by suitable connections of the transformers supplying the power to the load. Therefore it is usual to include LC branches tuned for the 5<sup>th</sup> and 7<sup>th</sup> harmonic order. The values of  $L_n$  and  $C_n$  parameter of a branch tuned for an “n” order harmonic must satisfy the equation.  $\omega_n = 2\pi f n = 1/\sqrt{L_n C_n}$  Where  $f$  corresponds to the fundamental frequency, that was taken as 50 Hz in this work. The active filter connected in series with the passive branches can be seen

as a controlled voltage source. Different strategies are possible to control this compensation voltage. In single-phase or balanced three-phase system, a voltage  $V_c$  proportional to source harmonic current  $I_{sh}$  permits to modify the impedance of the shunt compensator, and the passive filter performance is improved. Figure 2a shows the equivalent single-phase circuit for the compensated system. The non-linear load is modeled by a current source. For a determined harmonic of order  $H$ , the equivalent circuit is shown in figure 2b, it is possible to obtain the source harmonic current, equation 2

$$I_{SH} = Z_f / (Z_f + Z_s + K) I_{LH} + 1 / (Z_f + Z_s + K) V_{SH}$$

Where,  $Z_f$  – impedance of filter and  $Z_s$  – source impedance. Ideally, the source harmonic currents will be null if  $K = \infty$ . If  $K \gg (Z_s + Z_f)$  this strategy allows to reduce series resonance between the source and the filter. It avoids that the passive filter receives the harmonic current of the rest of the system. In the practical case simulated in this work a value  $K = 2$  is used. The output voltage of active power converter includes no desired high frequency harmonics caused by the switching devices operation. It is necessary to carry out a passive filtering. The series connection with the LC branches is carried out by means of a transformer. This allows to have low voltage values at the dc side of the inverter.

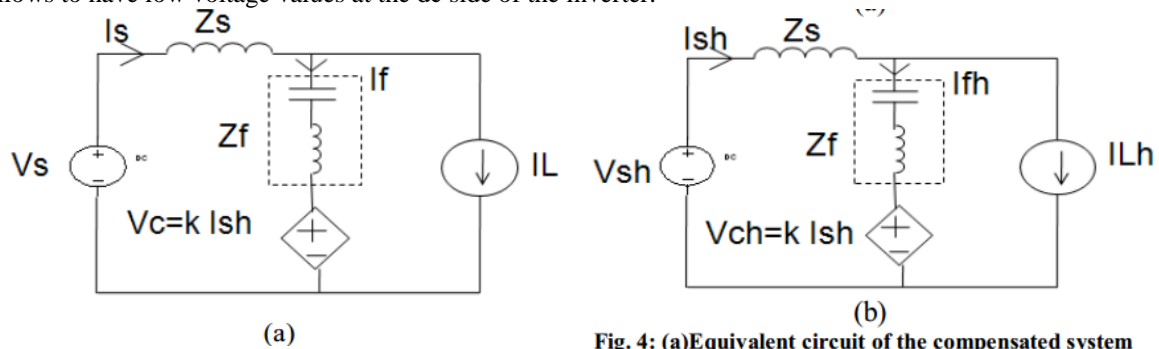

Fig. 4: (a)Equivalent circuit of the compensated system  
b)Equivalent circuit for harmonic of order H

### V. SIMULATION RESULTS

In this work three phase matrix converter has been compensated to check the hybrid filter performance. The source voltage is 440Vrms, 50Hz. Table 1 shows the compensated system main parameters. It includes source impedance parameters L and C values for passive branches used. The system has been simulated with passive filter, active filter and the hybrid filter separately. Table 1 shows the compensation system main parameter values. in simulation studies, the results are specified before and after applying the passive, active and hybrid filter to the matrix converter.

Table 1: Simulation Parameters

	Parameters		Value
Source	Voltage	Vsabc	440Vrms
	Frequency	F	50Hz
Load	3phase line inductance	L <sub>1abc</sub>	1mH
	3phase load resistance	RL	2 ohm
Filter	Inductance	Lcabc	4.05mH
	Capacitance	Ccabc	100µF

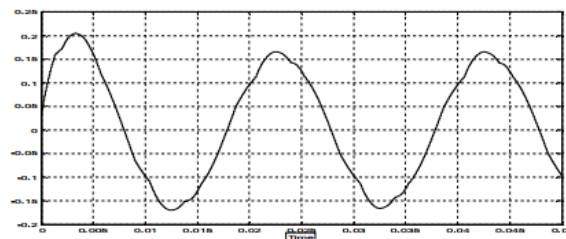

Fig. (a) Matrix Converter without filter

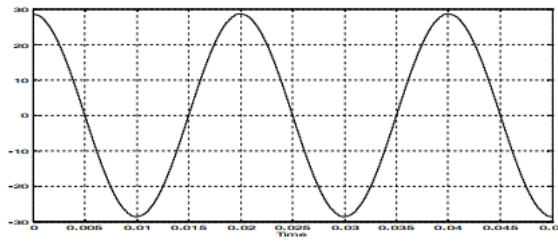

Fig. (b) Matrix Converter with passive filter

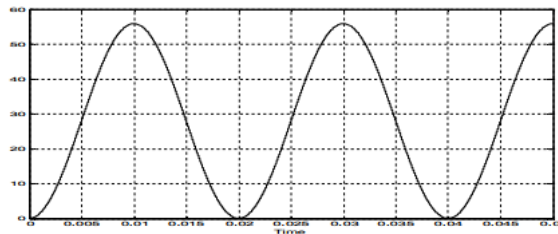

Fig. (c) Matrix Converter with active filter

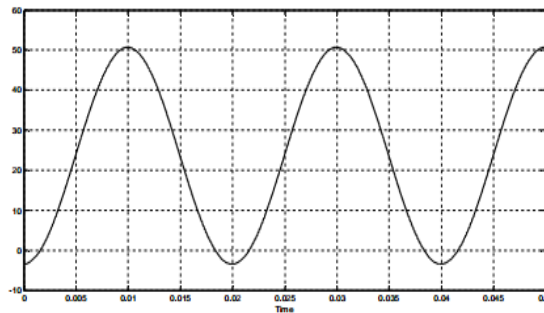

Fig. (d) Matrix Converter with hybrid filter

Fig.5: Source current waveforms in time domain for the system In figure a above, the source current waveforms for the matrix converter without applying any filter is shown. In the simulation the input current wave shape is non-sinusoidal and it contains harmonics. The simulation time is up to 0.05sec. In figure b, the matrix converter is operated by applying second order LC filter. the values for inductor and capacitor are shown in table 1. In figure c, the matrix converter is operated by applying a shunt active filter. The source current waveform is improved as compared to the passive filter. In figure c, the matrix converter is operated by applying a hybrid filter. The source current waveform is improved as compared to the passive filter and active filter. In this figure the source current waveform is almost sinusoidal.

## VI. CONCLUSION

In this paper a hybrid filter was used for power quality improvement in the matrix converter. The hybrid filter is constructed of a passive filter and a shunt active filter in series with it. This hybrid filter is connected in parallel with non linear load. The harmonic contents of the source current due to the nonlinear load is removed by the use of passive filter, active filter and the hybrid filter. Studying and comparing the waveforms of the source current, without any filter,with only passive filter, with only shunt active filter and with the hybrid filter it is found that the hybrid filter is better solution for the harmonic reduction in the matrix converter.

## REFERENCES

- [1] Jenopaul P, Ruban Deva Prakash T, Jacob Raglend I, "Adaptive PLL controller based shunt active filter for power quality improvement in Matrix converter" International Journal of Applied Engineering Research, dindigul volume 1,no 4,2011.
- [2] Farhad Shahnian, Seyed Hossein Hosseini, "Power Quality Improvement of PV Power Generation Systems Using Hybrid Filter"
- [3] Jusus R. Vazquez, Juan L. Flores, Patricio Salmeron, Salvador P. Litran, "A hybrid approach to compensate non-linear loads in electric power system"

- [4] Kennedy, Barry ,“ Power Quality Primer” Electrical engineering Primer Series, McGraw-Hill USA,1 Mar 2000
- [5] Tenti P., Malesani L., Rossetto L., “Optimum control of N –input K-output matrix converter” IEEE transaction on power electronics,7(4),pp. 707-713,1992
- [6] Huber L., Borojevic D., “Input filter design of forced commutated cycloconverter”, Proceedings of 6th Mediterranean Electrotechnical Conference,2,pp.1356-1359,1991
- [7] Gonzalo Sandoval, John Houdek, “A Review of Harmonic Mitigation Techniques”.
- [8] A. de Almeida, L. Moreira. J. Delgado,“Power Quality Problems and New Solutions” ISR – Department of Electrical and Computer Engineering University of Coimbra, Pólo II
- [9] P.Gani Raju, Veda Kumar.N, “Power Quality Improvement in DC Drives Using Matlab/Simulink” International Journal of Wisdom Based Computing, Vol. 1 (2), August 2011.
- [10] Ahmet Altintas , “A new method for power quality improvement in classical AC/AC voltage controllers using PWM technique” Scientific Research and Essays Vol. 5(10), pp. 1075-1083, 18 May, 2010.
- [11] P. Ferracci, “ Power Quality”, Schneider Electric Cahier Techniqu no.199, September 2000.
- [12] Cyril W. Lander, “ Power Electronics” Third Ed. McGraw Hill International Editions.
- [13] M.H.Rashid, “Power Electronics-circuit,devices and applications”, Prentice Hall of India Private Ltd.
- [14] H.Akagi, “Modern active filters and traditional passive filters”, Bulletin of the Polish Academy of Sciences,Technical Sciences,Vol. 54, No. 3, 2006.
- [15] Mr H. Bouchikha, M. Ghers, “Three phase shunt hybrid filters for the current harmonics suppression and the reactive power compensation”,European Journal of Scientific Research ISSN 1450-216X Vol.24 No.4(2008),pp.580-590
- [16] Antonio Martins 1, Jose Ferreira 2, Helder Azevedo 3, “Active Power Filter for Harmonic Elimination and Power Quality Improvement”
- [17] O.Ucak, I. Kocabas, A. Terciyani, “ Design and Implimentation of a Shunt Active Power Filter with Reduced DC Link Voltage”
- [18] G. Bhuvaneswari, Manjula G. Nair, “Three phase hybrid shunt filters for Power Quality Improvement”, Journal of Power Electronics, Vol.7, No.3, July 2007.